

Auto Bulk Behind Mirror Multi-Function Soap/ Sanitizer Dispenser 1200ML



The automatic multi-function soap dispensers with large soap capacity (1,200ml) has been designed for a behind mirror installation. The benefit of a large soap bottle is it can save the time and cost for soap-refilling. It uses our patented and alcohol resistant pumps: liquid, foam and spray and a simple change of the soap pump can convert the unit into a different type of automatic soap dispenser. There is also a smart LED indicator that will flash to indicate low battery status for the soap dispenser.



MULTI FUNCTION RANGE

Why HK-SSD PLUS-BM?



hands-free



AC adapter available



1000 ml soap bottle



battery life 145k uses



foam: one drop 0.7-1.0 ml



liquid: one drop 0.8-1.1 ml



interchangeable pump



no leakage problem



auto-detecting sensor



auto-detecting sensor



LED indicator



quiet operation



operating room



hospital



restaurant



shopping mall



postnatal care center



playground



kindergarten



public toilet

Specification

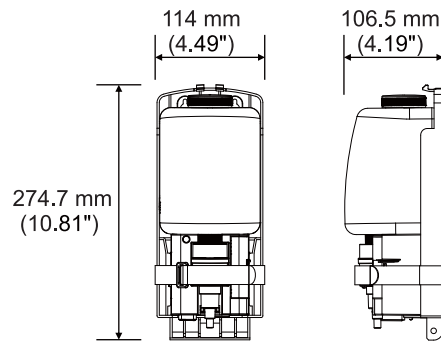

Packaging (carton):	HK-SSD1 / 2 PLUS-BM : 12 dispensers/carton. G.W. 8.9 kg. Meas. 3.37'
AC Type:	100-240V
Battery Type:	Alkaline AA (1.5V) x 4 pcs
Battery Life:	Liquid type: 25k drops/cycles Foam type: 25k drops/cycles Disinfectant spray: 16k drops/cycles
Soap Pump Life:	200k cycles
Mechanism Life:	500k cycles
Light Indication:	Flashing blue light: low batteries
Smart Design:	All key parts are independent for easy maintenance. Container assembly and mechanism of dispenser are 100% separation; mechanism is free from damage by soap.
Patented Soap Pump:	Prevent leakage problem Prevent leftover foam soap mess Suitable for liquid soap, liquid alcohol, alcohol gel, foam soap, sanitizer spray
Safety Approvals:	CE



